

DENON

SUPER AUDIO CD PLAYER

DCD-1510AE

Owner's Manual

Bedienungsanleitung

Manuel de l'Utilisateur

Manuale delle istruzioni

Manual del usuario

Gebruiksaanwijzing

Bruksanvisning

☐ SAFETY PRECAUTIONS



CAUTION
RISK OF ELECTRIC SHOCK
DO NOT OPEN



CAUTION:
TO REDUCE THE RISK OF ELECTRIC SHOCK, DO NOT REMOVE COVER (OR BACK). NO USER-SERVICEABLE PARTS INSIDE. REFER SERVICING TO QUALIFIED SERVICE PERSONNEL.

The lightning flash with arrowhead symbol, within an equilateral triangle, is intended to alert the user to the presence of uninsulated "dangerous voltage" within the product's enclosure that may be of sufficient magnitude to constitute a risk of electric shock to persons.

The exclamation point within an equilateral triangle is intended to alert the user to the presence of important operating and maintenance (servicing) instructions in the literature accompanying the appliance.

WARNING:
TO REDUCE THE RISK OF FIRE OR ELECTRIC SHOCK, DO NOT EXPOSE THIS APPLIANCE TO RAIN OR MOISTURE.

CLASS 1 LASER PRODUCT
LUOKAN 1 LASERLAITE
KLASS 1 LASERAPPARAT

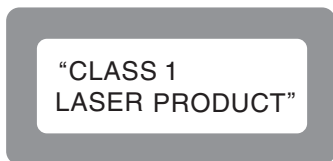

- ADVARSEL:** USYNLIG LASERSTRÅLING VED ÅBNING, NÅR SIKKERHEDSAFBRYDERE ER UDE AF FUNKTION. UNDGÅ UDSÆTTELSE FOR STRÅLING.
- VAROITUS!** LAITTEEN KÄYTTÄMINEN MUULLA KUIN TÄSSÄ KÄYTTÖOHJEESSA MAINITULLA TAVALLA SAATTAA ALTISTAA KÄYTTÄJÄN TURVALLISUUSLUOKAN 1 YLITTÄVÄLLE NÄKYMÄMTTÖMÄLLE LASERSÄTEILYLLE.
- WARNING:** OM APPARATEN ANVÄNDS PÅ ANNAT SÄTT ÄN I DENNA BRUKSANVISNING SPECIFICERATS, KAN ANVÄNDAREN UTSÄTTAS FÖR OSYNLIG LASERSTRÅLNING SOM ÖVERSKRIDER GRÄNSEN FÖR LASERKLASS 1.



ATTENZIONE: QUESTO APPARECCHIO E' DOTATO DI DISPOSITIVO OTTICO CON RAGGIO LASER. L'USO IMPROPRIO DELL'APPARECCHIO PUO' CAUSARE PERICOLOSE ESPOSIZIONI A RADIAZIONI!

IMPORTANT SAFETY INSTRUCTIONS

1. Read these instructions.
2. Keep these instructions.
3. Heed all warnings.
4. Follow all instructions.
5. Do not use this apparatus near water.
6. Clean only with dry cloth.
7. Do not block any ventilation openings. Install in accordance with the manufacturer's instructions.
8. Do not install near any heat sources such as radiators, heat registers, stoves, or other apparatus (including amplifiers) that produce heat.
9. Protect the power cord from being walked on or pinched particularly at plugs, convenience receptacles, and the point where they exit from the apparatus.
10. Only use attachments/accessories specified by the manufacturer.
11. Use only with the cart, stand, tripod, bracket, or table specified by the manufacturer, or sold with the apparatus. When a cart is used, use caution when moving the cart/apparatus combination to avoid injury from tip-over.
12. Unplug this apparatus during lightning storms or when unused for long periods of time.
13. Refer all servicing to qualified service personnel. Servicing is required when the apparatus has been damaged in any way, such as power-supply cord or plug is damaged, liquid has been spilled or objects have fallen into the apparatus, the apparatus has been exposed to rain or moisture, does not operate normally, or has been dropped.
14. Batteries shall not be exposed to excessive heat such as sunshine, fire or the like.



CAUTION:

To completely disconnect this product from the mains, disconnect the plug from the wall socket outlet.

The mains plug is used to completely interrupt the power supply to the unit and must be within easy access by the user.

VORSICHT:

Um dieses Gerät vollständig von der Stromversorgung abzutrennen, ziehen Sie bitte den Stecker aus der Wandsteckdose.

Der Netzstecker wird verwendet, um die Stromversorgung zum Gerät völlig zu unterbrechen; er muss für den Benutzer gut und einfach zu erreichen sein.

PRECAUTION:

Pour déconnecter complètement ce produit du courant secteur, débranchez la prise de la prise murale.

La prise secteur est utilisée pour couper complètement l'alimentation de l'appareil et l'utilisateur doit pouvoir y accéder facilement.

ATTENZIONE:

Per scollegare completamente questo prodotto dalla rete di alimentazione elettrica, scollegare la spina dalla relativa presa a muro.

La spina di rete viene utilizzata per interrompere completamente l'alimentazione all'unità e deve essere facilmente accessibile all'utente.

PRECAUCIÓN:

Para desconectar completamente este producto de la alimentación eléctrica, desconecte el enchufe del enchufe de la pared.

El enchufe de la alimentación eléctrica se utiliza para interrumpir por completo el suministro de alimentación eléctrica a la unidad y debe de encontrarse en un lugar al que el usuario tenga fácil acceso.

WAARSCHUWING:

Om de voeding van dit product volledig te onderbreken moet de stekker uit het stopcontact worden getrokken.

De netstekker wordt gebruikt om de stroomtoevoer naar het toestel volledig te onderbreken en moet voor de gebruiker gemakkelijk bereikbaar zijn.

FÖRSIKTIGHETSMÅTT:

Koppla loss stickproppen från eluttaget för att helt skilja produkten från nätet.

Stickproppen används för att helt bryta strömförsörjningen till apparaten, och den måste vara lättillgänglig för användaren.

CAUTION:

USE OF CONTROLS OR ADJUSTMENTS OR PERFORMANCE OF PROCEDURES OTHER THAN THOSE SPECIFIED HEREIN MAY RESULT IN HAZARDOUS RADIATION EXPOSURE.

THIS PRODUCT SHOULD NOT BE ADJUSTED OR REPAIRED BY ANYONE EXCEPT PROPERLY QUALIFIED SERVICE PERSONNEL.

□ **NOTE ON USE / HINWEIS ZUM GEBRAUCH / OBSERVATIONS RELATIVES A L'UTILISATION / NOTE SULL'USO / NOTAS SOBRE EL USO / ALVORENSTE GEBRUIKEN / OBSERVERA ANGÅENDE ANVÄNDNINGEN**

WARNINGS	WARNHINWEISE	AVERTISSEMENTS	AVVERTENZE	ADVERTENCIAS	WAARSCHUWINGEN	VARNINGAR
<ul style="list-style-type: none"> • Avoid high temperatures. Allow for sufficient heat dispersion when installed in a rack. • Handle the power cord carefully. Hold the plug when unplugging the cord. • Keep the unit free from moisture, water, and dust. • Unplug the power cord when not using the unit for long periods of time. • Do not obstruct the ventilation holes. • Do not let foreign objects into the unit. • Do not let insecticides, benzene, and thinner come in contact with the unit. • Never disassemble or modify the unit in any way. • Ventilation should not be impeded by covering the ventilation openings with items, such as newspapers, tablecloths or curtains. • Naked flame sources such as lighted candles should not be placed on the unit. • Observe and follow local regulations regarding battery disposal. • Do not expose the unit to dripping or splashing fluids. • Do not place objects filled with liquids, such as vases, on the unit. • Do not handle the mains cord with wet hands. • When the switch is in the OFF position, the equipment is not completely switched off from MAINS. • The equipment shall be installed near the power supply so that the power supply is easily accessible. 	<ul style="list-style-type: none"> • Vermeiden Sie hohe Temperaturen. Beachten Sie, dass eine ausreichende Belüftung gewährleistet wird, wenn das Gerät auf ein Regal gestellt wird. • Gehen Sie vorsichtig mit dem Netzkabel um. Halten Sie das Kabel am Stecker, wenn Sie den Stecker herausziehen. • Halten Sie das Gerät von Feuchtigkeit, Wasser und Staub fern. • Wenn das Gerät längere Zeit nicht verwendet werden soll, trennen Sie das Netzkabel vom Netzstecker. • Decken Sie den Lüftungsbereich nicht ab. • Lassen Sie keine fremden Gegenstände in das Gerät kommen. • Lassen Sie das Gerät nicht mit Insektiziden, Benzin oder Verdünnungsmitteln in Berührung kommen. • Versuchen Sie niemals das Gerät auseinander zu nehmen oder zu verändern. • Die Belüftung sollte auf keinen Fall durch das Abdecken der Belüftungsöffnungen durch Gegenstände wie beispielsweise Zeitungen, Tischtücher, Vorhänge o. Ä. behindert werden. • Auf dem Gerät sollten keinerlei direkte Feuerquellen wie beispielsweise angezündete Kerzen aufgestellt werden. • Bitte beachten Sie bei der Entsorgung der Batterien die örtlich geltenden Umweltbestimmungen. • Das Gerät sollte keiner tropfenden oder spritzenden Flüssigkeit ausgesetzt werden. • Auf dem Gerät sollten keine mit Flüssigkeit gefüllten Behälter wie beispielsweise Vasen aufgestellt werden. • Das Netzkabel nicht mit feuchten oder nassen Händen anfassen. • Wenn der Schalter ausgeschaltet ist (OFF-Position), ist das Gerät nicht vollständig vom Stromnetz (MAINS) abgetrennt. • Das Gerät sollte in der Nähe einer Netzsteckdose aufgestellt werden, damit es leicht an das Stromnetz angeschlossen werden kann. 	<ul style="list-style-type: none"> • Eviter des températures élevées. Tenir compte d'une dispersion de chaleur suffisante lors de l'installation sur une étagère. • Manipuler le cordon d'alimentation avec précaution. Tenir la prise lors du débranchement du cordon. • Protéger l'appareil contre l'humidité, l'eau et la poussière. • Débrancher le cordon d'alimentation lorsque l'appareil n'est pas utilisé pendant de longues périodes. • Ne pas obstruer les trous d'aération. • Ne pas laisser des objets étrangers dans l'appareil. • Ne pas mettre en contact des insecticides, du benzène et un diluant avec l'appareil. • Ne jamais démonter ou modifier l'appareil d'une manière ou d'une autre. • Ne pas recouvrir les orifices de ventilation avec des objets tels que des journaux, nappes ou rideaux. Cela entraverait la ventilation. • Ne jamais placer de flamme nue sur l'appareil, notamment des bougies allumées. • Veillez à respecter les lois en vigueur lorsque vous jetez les piles usagées. • L'appareil ne doit pas être exposé à l'eau ou à l'humidité. • Ne pas poser d'objet contenant du liquide, par exemple un vase, sur l'appareil. • Ne pas manipuler le cordon d'alimentation avec les mains mouillées. • Lorsque l'interrupteur est sur la position OFF, l'appareil n'est pas complètement déconnecté du SECTEUR (MAINS). • L'appareil sera installé près de la source d'alimentation, de sorte que cette dernière soit facilement accessible. 	<ul style="list-style-type: none"> • Evitate di esporre l'unità a temperature elevate. Assicuratevi che vi sia un'adeguata dispersione del calore quando installate l'unità in un mobile per componenti audio. • Maneggiate il cavo di alimentazione con attenzione. Tenete ferma la spina quando scollegate il cavo dalla presa. • Tenete l'unità lontana dall'umidità, dall'acqua e dalla polvere. • Scollegate il cavo di alimentazione quando prevedete di non utilizzare l'unità per un lungo periodo di tempo. • Non coprite i fori di ventilazione. • Non inserite corpi estranei all'interno dell'unità. • Assicuratevi che l'unità non entri in contatto con insetticidi, benzolo o solventi. • Non smontate né modificate l'unità in alcun modo. • Le aperture di ventilazione non devono essere ostruite coprendole con oggetti, quali giornali, tovaglie, tende e così via. • Non posizionate sull'unità fi amme libere, come ad esempio candele accese. • Prestate attenzione agli aspetti legati alla tutela dell'ambiente nello smaltimento delle batterie. • L'apparecchiatura non deve essere esposta a goccioli o spruzzi. • Non posizionate sull'unità alcun oggetto contenente liquidi, come ad esempio i vasi. • Non toccare il cavo di alimentazione con le mani bagnate. • Quando l'interruttore è nella posizione OFF, l'apparecchiatura non è completamente scollegata da MAINS. • L'apparecchio va installato in prossimità della fonte di alimentazione, in modo che quest'ultima sia facilmente accessibile. 	<ul style="list-style-type: none"> • Evite altas temperaturas. Permita la suficiente dispersión del calor cuando está instalado en la consola. • Maneje el cordón de energía con cuidado. Sostenga el enchufe cuando desconecte el cordón de energía. • Mantenga el equipo libre de humedad, agua y polvo. • Desconecte el cordón de energía cuando no utilice el equipo por mucho tiempo. • No obstruya los orificios de ventilación. • No deje objetos extraños dentro del equipo. • No permita el contacto de insecticidas, gasolina y diluyentes con el equipo. • Nunca desarme o modifique el equipo de ninguna manera. • La ventilación no debe quedar obstruida por haberse cubierto las aperturas con objetos como periódicos, manteles o cortinas. • No deberán colocarse sobre el aparato fuentes inflamables sin protección, como velas encendidas. • A la hora de deshacerse de las pilas, respete la normativa para el cuidado del medio ambiente. • No exponer el aparato al goteo o salpicaduras cuando se utilice. • No colocar sobre el aparato objetos llenos de líquido, como jarras. • No maneje el cable de alimentación con las manos mojadas. • Cuando el interruptor está en la posición OFF, el equipo no está completamente desconectado de la alimentación MAINS. • El equipo se instalará cerca de la fuente de alimentación de manera que resulte fácil acceder a ella. 	<ul style="list-style-type: none"> • Vermijd hoge temperaturen. Zorg er bij installatie in een audiorack voor, dat de door het toestel geproduceerde warmte goed kan worden afgevoerd. • Hanteer het netsnoer voorzichtig. Houd het snoer bij de stekker vast wanneer deze moet worden aan- of losgekoppeld. • Laat geen vochtigheid, water of stof in het apparaat binnendringen. • Neem altijd het netsnoer uit het stopcontact wanneer het apparaat gedurende een lange periode niet wordt gebruikt. • De ventilatieopeningen mogen niet worden geblokkeerd. • Laat geen vreemde voorwerpen in dit apparaat vallen. • Voorkom dat insecticiden, benzene of verfvendunners met dit toestel in contact komen. • Dit toestel mag niet gedemonteerd of aangepast worden. • De ventilatie mag niet worden belemmerd door de ventilatieopeningen af te dekken met bijvoorbeeld kranten, een tafelkleed of gordijnen. • Plaats geen open vlammen, bijvoorbeeld een brandende kaars, op het apparaat. • Houd u steeds aan de milieuvoorschriften wanneer u gebruikte batterijen wegdoet. • Stel het apparaat niet bloot aan druppels of spatten. • Plaats geen voorwerpen gevuld met water, bijvoorbeeld een vaas, op het apparaat. • Raak het netsnoer niet met natte handen aan. • Als de schakelaar op OFF staat, is het apparaat niet volledig losgekoppeld van de netspanning (MAINS). • De apparatuur wordt in de buurt van het stopcontact geïnstalleerd, zodat dit altijd gemakkelijk toegankelijk is. 	<ul style="list-style-type: none"> • Undvik höga temperaturer. Se till att det finns möjlighet till god värmeavledning vid montering i ett rack. • Hantera nätkabeln varsamt. Håll i kabeln när den kopplas från el-uttaget. • Utsätt inte apparaten för fukt, vatten och damm. • Koppla loss nätkabeln om apparaten inte kommer att användas i lång tid. • Täpp inte till ventilationsöppningarna. • Se till att främmande föremål inte tränger in i apparaten. • Se till att inte insektsmedel på spraybruk, bensen och thinner kommer i kontakt med apparatens hölje. • Ta inte isär apparaten och försök inte bygga om den. • Ventilationen bör inte förhindras genom att täcka för ventilationsöppningarna med föremål såsom tidningar, bordsdukar eller gardiner. • Placera inte öppen eld, t.ex. tända ljus, på apparaten. • Tänk på miljöaspekterna när du bortskaffar batterier. • Apparaten får inte utsättas för vätska. • Placera inte föremål fyllda med vätska, t.ex. vaser, på apparaten. • Hantera inte nätsladden med våta händer. • Även om strömbrytaren står i det avstängda läget OFF, så är utrustningen inte helt bortkopplad från det elektriska nätet (MAINS). • Utrustningen ska vara installerad nära strömuttaget så att strömförsörjningen är lätt att tillgå.

• DECLARATION OF CONFORMITY

We declare under our sole responsibility that this product, to which this declaration relates, is in conformity with the following standards: EN60065, EN55013, EN55020, EN61000-3-2 and EN61000-3-3. Following the provisions of Low Voltage Directive 2006/95/EC and EMC Directive 2004/108/EC, the EC regulation 1275/2008 and its frame work Directive 2009/125/EC for Energy-related Products (ErP).

• ÜBEREINSTIMMUNGSERKLÄRUNG

Wir erklären unter unserer Verantwortung, daß dieses Produkt, auf das sich diese Erklärung bezieht, den folgenden Standards entspricht: EN60065, EN55013, EN55020, EN61000-3-2 und EN61000-3-3. Following the provisions of low voltage directive 2006/95/EC and EMC directive 2004/108/EC, the EC regulation 1275/2008 and its frame work directive 2009/125/EC for energy-related products (ErP).

• DECLARATION DE CONFORMITE

Nous déclarons sous notre seule responsabilité que l'appareil, auquel se réfère cette déclaration, est conforme aux standards suivants: EN60065, EN55013, EN55020, EN61000-3-2 et EN61000-3-3. Selon la directive 2006/95/EC concernant la basse tension et la directive CEM 2004/108/EC, la réglementation européenne 1275/2008 et la directive 2009/125/EC établissant un cadre de travail applicable aux produits liés à l'énergie (ErP).

• DICHIARAZIONE DI CONFORMITÀ

Dichiaro con piena responsabilità che questo prodotto, al quale la nostra dichiarazione si riferisce, è conforme alle seguenti normative: EN60065, EN55013, EN55020, EN61000-3-2 e EN61000-3-3. Facendo seguito alle disposizioni della direttiva sul basso voltaggio 2006/95/EC alla direttiva EMC 2004/108/EC, alla norma EC 1275/2008 e alla relativa legge quadro 2009/125/EC in materia di prodotti alimentati ad energia (ErP).

QUESTO PRODOTTO E' CONFORME AL D.M. 28/08/95 N. 548

• DECLARACIÓN DE CONFORMIDAD

Declaramos bajo nuestra exclusiva responsabilidad que este producto al que hace referencia esta declaración, está conforme con los siguientes estándares: EN60065, EN55013, EN55020, EN61000-3-2 y EN61000-3-3. De acuerdo con la directiva sobre baja tensión 2006/95/CE y la directiva sobre CEM 2004/108/CE, la normativa CE 1275/2008 y su directiva marco 2009/125/EC para productos relacionados con la energía (ErP).

• EENVORMIGHEIDSVERKLARING

Wij verklaren uitsluitend op onze verantwoordelijkheid dat dit produkt, waarop deze verklaring betrekking heeft, in overeenstemming is met de volgende normen: EN60065, EN55013, EN55020, EN61000-3-2 en EN61000-3-3. Volgens de voorzieningen van lage spanningsrichtlijn 2006/95/EC en EMC-richtlijn 2004/108/EC, de EU-richtlijn 1275/2008 en de kaderrichtlijn 2009/125/EC voor energieverbruikende producten (ErP).

• ÖVERENSSTÄMMELSESINTYG

Härmed intygas helt på eget ansvar att denna produkt, vilken detta intyg avser, uppfyller följande standarder: EN60065, EN55013, EN55020, EN61000-3-2 och EN61000-3-3. Uppfyller reglerna i lågspänningsdirektivet 2006/95/EC och EMC-direktivet 2004/108/EC, EU-förordningen 1275/2008 och ramverksdirektivet 2009/125/EC för energirelaterade produkter (ErP).

DENON EUROPE
Division of D&M Germany GmbH
An der Kleinbahn 18, Nettelal,
D-41334 Germany

A NOTE ABOUT RECYCLING:

This product's packaging materials are recyclable and can be reused. Please dispose of any materials in accordance with the local recycling regulations. When discarding the unit, comply with local rules or regulations. Batteries should never be thrown away or incinerated but disposed of in accordance with the local regulations concerning battery disposal. This product and the supplied accessories, excluding the batteries, constitute the applicable product according to the WEEE directive.

HINWEIS ZUM RECYCLING:

Das Verpackungsmaterial dieses Produktes ist zum Recyceln geeignet und kann wieder verwendet werden. Bitte entsorgen Sie alle Materialien entsprechend der örtlichen Recycling-Vorschriften. Beachten Sie bei der Entsorgung des Gerätes die örtlichen Vorschriften und Bestimmungen. Die Batterien dürfen nicht in den Hausmüll geworfen oder verbrannt werden; bitte entsorgen Sie die Batterien gemäß der örtlichen Vorschriften.

Dieses Produkt und das im Lieferumfang enthaltene Zubehör (mit Ausnahme der Batterien!) entsprechen der WEEE-Direktive.

UNE REMARQUE CONCERNANT LE RECYCLAGE:

Les matériaux d'emballage de ce produit sont recyclables et peuvent être réutilisés. Veuillez disposer des matériaux conformément aux lois sur le recyclage en vigueur. Lorsque vous mettez cet appareil au rebut, respectez les lois ou réglementations en vigueur. Les piles ne doivent jamais être jetées ou incinérées, mais mises au rebut conformément aux lois en vigueur sur la mise au rebut des piles. Ce produit et les accessoires inclus, à l'exception des piles, sont des produits conformes à la directive DEEE.

NOTA RELATIVA AL RICICLAGGIO:

I materiali di imballaggio di questo prodotto sono riutilizzabili e riciclabili. Smaltire i materiali conformemente alle normative locali sul riciclaggio. Per lo smaltimento dell'unità, osservare le normative o le leggi locali in vigore. Non gettare le batterie, né incenerirle, ma smaltirle conformemente alla normativa locale sui rifiuti chimici. Questo prodotto e gli accessori inclusi nell'imballaggio sono applicabili alla direttiva RAEE, ad eccezione delle batterie.

ACERCA DEL RECICLAJE:

Los materiales de embalaje de este producto son reciclables y se pueden volver a utilizar. Disponga de estos materiales siguiendo los reglamentos de reciclaje de su localidad. Cuando se deshaga de la unidad, cumpla con las reglas o reglamentos locales. Las pilas nunca deberán tirarse ni incinerarse. Deberá disponer de ellas siguiendo los reglamentos de su localidad relacionados con los desperdicios químicos. Este producto junto con los accesorios empaquetados es el producto aplicable a la directiva RAEE excepto pilas.

EEN AANTEKENING MET BETREKKING TOT DE RECYCLING:

Het inpakmateriaal van dit product is recycleerbaar en kan opnieuw gebruikt worden. Er wordt verzocht om zich van elk afvalmateriaal te ontdoen volgens de plaatselijke voorschriften. Volg voor het wegdoen van de speler de voorschriften voor de verwijdering van wit- en bruingoed op. Batterijen mogen nooit worden weggegooid of verbrand, maar moeten volgens de plaatselijke voorschriften betreffende chemisch afval worden verwijderd. Op dit product en de meegeleverde accessoires, m.u.v. de batterijen is de richtlijn voor afgedankte elektrische en elektronische apparaten (WEEE) van toepassing.

OBSERVERA ANGÅENDE ÅTERVINNING:

Produktens emballage är återvinningsbart och kan återanvändas. Kassera det enligt lokala återvinningsbestämmelser. När du kasserar enheten ska du göra det i överensstämmelse med lokala regler och bestämmelser. Batterier får absolut inte kastas i soporna eller brännas. Kassera dem enligt lokala bestämmelser för kemiskt avfall. Denna apparat och de tillbehör som levereras med den uppfyller gällande WEEE-direktiv, med undantag av batterierna.



Pb

**□ CAUTIONS ON INSTALLATION
VORSICHTSHINWEISE ZUR AUFSTELLUNG
PRÉCAUTIONS D'INSTALLATION
PRECAUZIONI SULL'INSTALLAZIONE
EMPLAZAMIENTO DE LA INSTALACIÓN
VOORZORGSMAATREGELEN BIJ DE INSTALLATIE
FÖRSIKTIGHET VID INSTALLATIONEN**

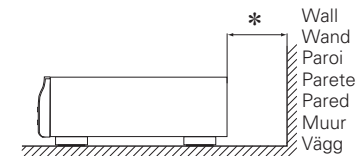
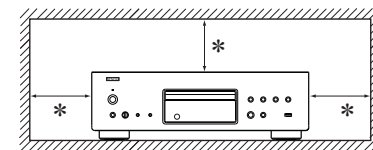

* For proper heat dispersal, do not install this unit in a confined space, such as a bookcase or similar enclosure.

- More than 0.1 m is recommended.
- Do not place any other equipment on this unit.

* Stellen Sie das Gerät nicht an einem geschlossenen Ort, wie in einem Bücherregal oder einer ähnlichen Einrichtung auf, da dies eine ausreichende Belüftung des Geräts behindern könnte.

- Empfohlen wird über 0,1 m.
- Keine anderen Gegenstände auf das Gerät stellen.

* Pour permettre la dissipation de chaleur requise, n'installez pas cette unité dans un espace confiné tel qu'une bibliothèque ou un endroit similaire.

- Une distance de plus de 0,1 m est recommandée.
- Ne placez aucun matériel sur cet appareil.

* Per una dispersione adeguata del calore, non installare questa apparecchiatura in uno spazio ristretto, come ad esempio una libreria o simili.

- Si raccomanda una distanza superiore ai 0,1 m.
- Non posizionare alcun altro oggetto o dispositivo su questo dispositivo.

* Para la dispersión del calor adecuadamente, no instale este equipo en un lugar confinado tal como una librería o unidad similar.

- Se recomienda dejar más de 0,1 m alrededor.
- No coloque ningún otro equipo sobre la unidad.

* Plaats dit toestel niet in een kleine afgesloten ruimte, zoals een boekenkast e.d., omdat anders de warmte niet op gepaste wijze kan worden afgevoerd.

- Meer dan 0,1 m is aanbevolen.
- Plaats geen andere apparatuur op het toestel.

* För att tillförsäkra god värmeavledning får utrustningen inte installeras i instängda utrymmen, som t.ex. en bokhylla eller liknande.

- Mer än 0,1 m rekommenderas.
- Placera ingen annan utrustning ovanpå den här enheten.

Contents

Getting started	1
Accessories	1
Main features	2
Cautions on handling	2
Discs	2
Discs playable on this unit	2
Holding discs	2
Loading discs	2
Cautions on loading discs	2
Cautions on handling	3
Cautions on storing discs	3
Cleaning discs	3
About the remote control	3
Inserting the batteries	3
Operating range of the remote control	3
Part names and functions	4
Front panel	4
Display	4
Rear panel	5
Remote control	5
Basic connections	6
Preparations	6
Connecting cables	6
Analog connections	6
Connecting the power cord	6
Basic operation	7
Before use	7
Setting the top priority playback layer for super audio CDs	7
Turning the power off	7
Playback CDs	8
Playing CDs	8
Displaying text (Super Audio CD only)	8
Listening with headphone	8
Playing repeatedly (Repeat playback)	9
Playing in random order	9
(Random playback)	9
Playing tracks in a specific order	9
(Program playback)	9

Advanced connections	10
Preparations	10
Connecting cables	10
Digital connections	10
USB port connections	10
USB memory device	10
iPod	10

Advanced operations	11
Operations possible during playback	11
Switching the display's brightness	11
Switching the pure direct mode	11
To change time display	11
Eco mode setting	11
Before playing a USB or an iPod	12
Playback of MP3 and WMA files	12
MP3 and WMA formats	12
Playing MP3 and WMA files	12
MP3 or WMA Playback order of MP3 or WMA files	13
Playback iPod®	14
Playing iPod®	14
Disconnecting the iPod	14
USB playback	15
Playable USB memory formats	15
Playing USB memory devices	15
Using the timer play function	16

Explanation of terms	16
Troubleshooting	17
Specifications	18
Index	18

Getting started

Thank you for purchasing this DENON product. To ensure proper operation, please read this owner's manual carefully before using the product. After reading the manual, be sure to keep it for future reference.

Accessories

Check that the following parts are supplied with the product.

① Owner's manual	1
② Service network list	1
③ Power cord (Cord length: Approx. 1.5 m)	1
④ Remote control (RC-1143)	1
⑤ R03/AAA battery	2
⑥ Audio cable (Cord length: Approx. 1.0 m)	1

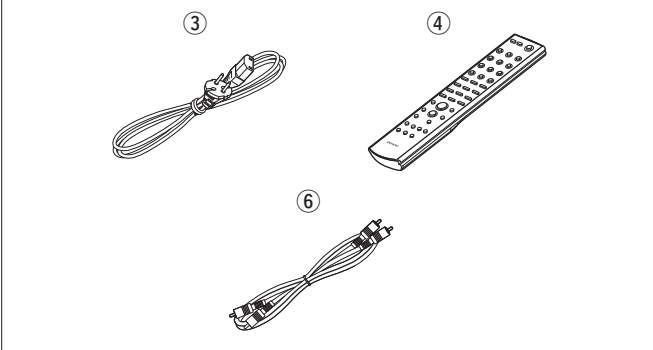

• Note that for explanatory purposes the illustrations in these instructions may differ from the actual unit.

Main features

Advanced AL32 Processing and High-precision 32bit D/A Converter

Equipped with Advanced AL32 Processing, DENON's proprietary analog waveform reproduction technology. We have enhanced the reproducibility of weak signals by expanding 16 bit digital data to 32 bit. The player is also equipped with a high-performance, 32 bit/192 kHz-compatible D/A Converter for analog signal conversion of the digital data expanded with Advanced AL32 Processing.

Playback of MP3 and WMA files

A USB port is mounted on the front panel. MP3/WMA files can be played by connecting a USB Player, USB memory device. Connect your iPod with the USB cable that came with it. Music files in an iPod, USB Player or USB memory device are transmitted via digital signal and can be enjoyed at high audio quality using the unit's own audio circuitry.

Cautions on handling

• Before turning the power switch on

Check once again that all connections are correct and that there are no problems with the connection cables.

- When leaving home for long periods of time, be sure to unplug the power cord from the power outlet.

• Proper ventilation

If the unit is left in a room full of the smoke from cigarettes, etc., for long periods of time, the surface of the optical pickup may get dirty, preventing it from receiving the signals properly.

• About condensation

If there is a major difference in temperature between the inside of the unit and its surroundings, condensation may form on parts inside the unit, causing the unit to fail to operate properly.

If this happens, let the unit sit for an hour or two with the power off and wait until there is little difference in temperature before using the unit.

• Cautions on using mobile phones

Using a mobile phone near this unit may result in noise. If that occurs, move the mobile phone away from the unit when it is in use.

• Moving the unit

Turn off the power and unplug the power cord from the power outlet. Next, disconnect the cables connected to other system units before moving the unit.

Discs

Discs playable on this unit

① Super Audio CDs

Super Audio CDs with the following logos indicated below can be played on this unit.



SUPER AUDIO CD

Stereo Multi-ch

② Music CDs

Discs marked with the logo at right can be played in this unit.



③ CD-R/CD-RW

NOTE

- Discs in special shapes (heart-shaped discs, octagonal discs, etc.) cannot be played. Do not attempt to play them, as doing so can damage the unit.
- Some discs and some recording formats cannot be played.
- Non-finalized discs cannot be played.



※ What is finalization?

Finalization is the process that makes recorded CD-R/CD-RW discs playable on compatible players.

Holding discs



Do not touch the signal surface.

Loading discs

- Place the disc in the tray, label side up.
- Make sure the disc tray is fully open when inserting the disc.
- Place the discs flat, 12 cm discs in the outer tray guide (Figure 1), 8 cm discs in the inner tray guide (Figure 2).

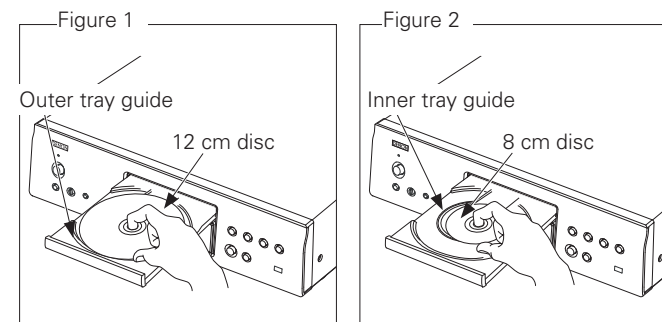

- Place 8 cm discs in the inner tray guide without using an adapter.



- "TRACK0 0m00s" is displayed if a disc that cannot be played is loaded.
- "NO DISC" is displayed if the disc is loaded upside-down or if no disc is loaded.

NOTE

Do not push the disc tray in by hand when the power is turned off. Doing so could damage the unit.

Cautions on loading discs

- Only load one disc at a time. Loading two or more discs can damage the unit or scratch the discs.
- Do not use cracked or warped discs or discs that have been repaired with adhesive, etc.
- Do not use discs on which the sticky part of cellophane tape or labels is exposed or on which there are traces of where labels have been removed. Such discs can get caught inside the player and damage it.

Cautions on handling

- Do not get fingerprints, oil or dirt on discs.
- Take special care not to scratch discs when removing them from their cases.
- Do not bend or heat discs.
- Do not enlarge the hole in the center.
- Do not write on the labeled (printed) surface with ball-point pens, pencils, etc., or stick new labels on discs.
- Water droplets may form on discs if they are moved suddenly from a cold place (outdoors for example) to a warm place, but do not try to dry them off using a hairdryer, etc.

Cautions on storing discs

- Be sure to remove discs after using them.
- Be sure to store discs in their cases to protect them from dust, scratches, warping, etc.
- Do not store discs in the following places:
 1. Places exposed to direct sunlight for long periods of time
 2. Dusty or humid places
 3. Places exposed to heat from heaters, etc.

Cleaning discs

- If there are fingerprints or dirt on a disc, wipe them off before using the disc. Fingerprints and dirt can impair sound quality and cause interruptions in playback.
- Use a commercially available disc cleaning set or a soft cloth to clean discs.

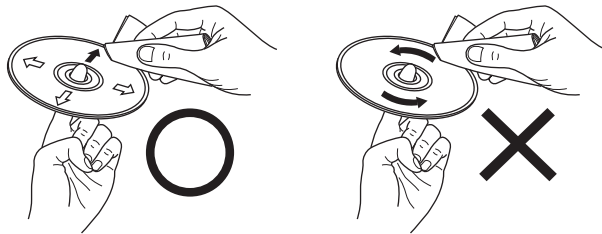

Gently wipe the disc from the inside towards the outside.

Do not wipe in a circular motion.

NOTE

Do not use record spray, antistatic agents, benzene, thinner or other solvents.

About the remote control

Inserting the batteries

- ① Remove the rear cover of the remote control.
- ② Set two R03/AAA batteries in the battery compartment in the indicated direction.

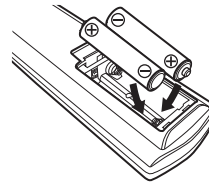
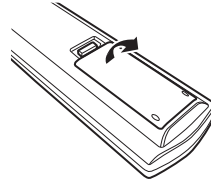

- ③ Put the rear cover back on.

NOTE

- Replace the batteries with new ones if the unit does not operate even when the remote control is operated close to the unit.
- The supplied batteries are only for verifying operation.
- Insert the batteries in the proper direction, following the “⊕” and “⊖” marks in the battery compartment.
- To prevent damage or leakage of battery fluid:
 - Do not use a new battery with an old one.
 - Do not use two different types of batteries.
 - Do not attempt to charge dry batteries.
 - Do not short-circuit, disassemble, heat or dispose of batteries in a fire.
- If the battery fluid leaks, carefully wipe the fluid off the inside of the battery compartment and insert new batteries.
- Remove the batteries from the remote control if it will not be used for a long time.
- Dispose of batteries in accordance with local regulations on battery disposal.

Operating range of the remote control

operate the remote control while pointing it at the remote sensor.

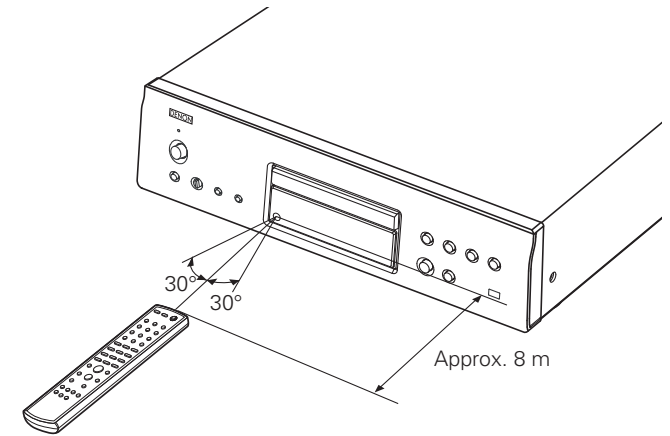

NOTE

The unit may function improperly or the remote control may not operate if the remote control sensor is exposed to direct sunlight or strong artificial light from a fluorescent or infrared light.

Part names and functions

For buttons not explained here, see the page indicated in parentheses ().

Front panel

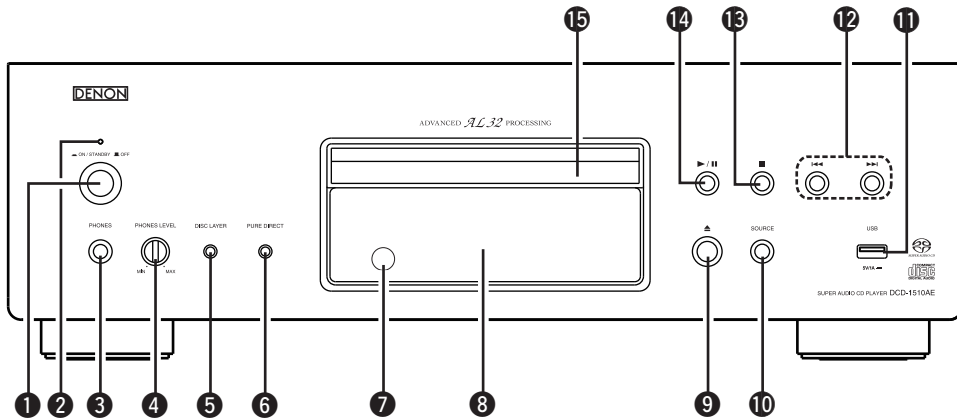

- 1 Power switch** (ON/STANDBY OFF) .. (7)
- 2 Power indicator** (7)
 - Power "ON" Green
 - Standby Red
 - Power "OFF" Off
 - Eco Mode Standby Off
- 3 Headphones Jack (PHONES)** (8)
- 4 Volume control (PHONES LEVEL)** (8)
- 5 DISC LAYER button** (7)
- 6 PURE DIRECT button** (11)
- 7 Remote control sensor** (3)
- 8 Display** (4)
- 9 Disc tray open/close button** (▲) (8)
- 10 SOURCE button** (7)
- 11 USB port (USB)** (10)
- 12 Reverse-skip/Forward-skip buttons** (◀▶) (8)
- 13 Stop button** (■) (8)
- 14 Play/Pause button** (▶/||) (8)
- 15 Disc tray** (2)

Display

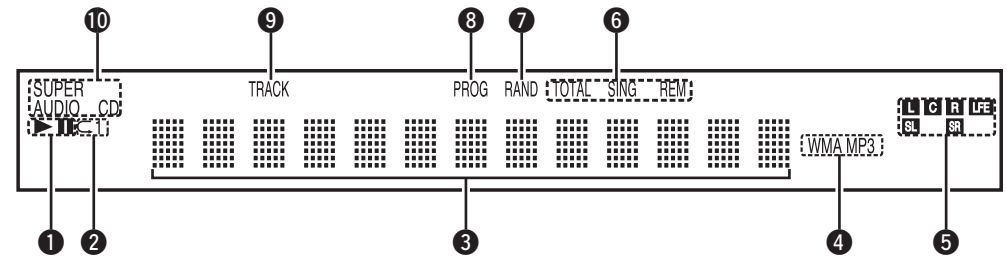

- 1 Playback mode indicators**
 - ▶ : During Playback
 - || : During pause
- 2 Repeat mode indicators**

The display switches as follows each time the **REPEAT** button on the remote control is pressed.

▶ C 1
▶ C

(1-track repeat)
(All-track repeat)

Not displayed
(Repeat off)
- 3 Information display**

Various information is displayed here, depending on the operation mode.
- 4 Playback format indicators**
- 5 Playback signal channel indicator**

L : Front left	LFE : Subwoofer
C : Center	SL : Surround left
R : Front right	SR : Surround right
- 6 Time display indicator**

SING REM : Lights up when displaying the remaining time in single-track playback.

TOTAL REM : Lights up when displaying the remaining time in all-track playback.
- 7 Random indicator**

Lights up during random playback.
- 8 Program indicator**

Lights up during program playback.
- 9 Track number indicator**

Lights up when displaying the track number.
- 10 Playback media indicator**

NOTE

In FOLDER mode, the "MP3" or "WMA" indicator flashes.

Rear panel

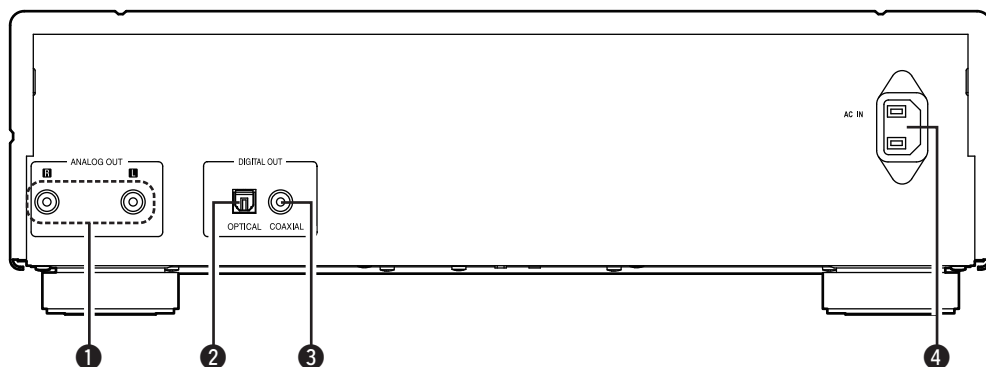

- 1 ANALOG OUT connectors (6)
- 2 DIGITAL OUT OPTICAL connector (10)
- 3 DIGITAL OUT COAXIAL connector (10)
- 4 AC inlet (AC IN) (6)

Remote control

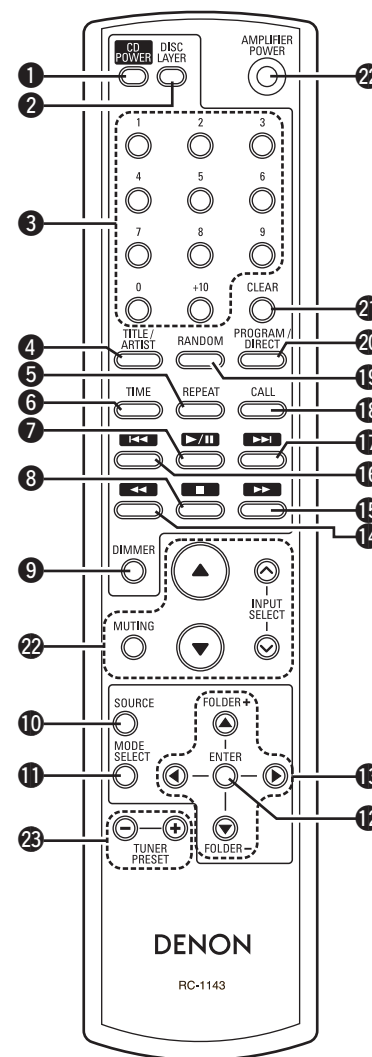

- 1 CD POWER button (7)
- 2 DISC LAYER button (7)
- 3 Number buttons (0 – 9, +10) (8)
- 4 TITLE/ARTIST button (8)
- 5 REPEAT button (9)
- 6 TIME button (11)
- 7 Play/Pause button (▶/⏸) (8)
- 8 Stop button (■) (8)
- 9 DIMMER button (11)
- 10 SOURCE button (7)
- 11 MODE SELECT button (13)
- 12 ENTER button (13)
- 13 Cursor buttons (Δ ▽ ◀ ▶) (13)
- 14 Fast-reversing button (◀◀) (8)
- 15 Fast-forwarding button (▶▶) (8)
- 16 Reverse-skip button (◀◀|) (8)
- 17 Forward-skip button (▶▶|) (8)
- 18 CALL button (9)
- 19 RANDOM button (9)
- 20 PROGRAM/DIRECT button (9)
- 21 CLEAR button (9)

- 22 AMP operation
- 23 Tuner operation



- The supplied remote control can operate DENON amplifiers/tuners.
- When using it, also refer to the operating instructions of the other devices.
- The remote control may not operate some devices.

Basic connections

Connections for all compatible audio signal formats are described in this owner's manual. Please select the type of connections corresponding to the equipment you are connecting.

NOTE

- Do not plug in the power cord until all connections have been completed.
- When making connections, also refer to the owner's manual of the other components.
- Be sure to connect the left and right channels properly (left with left, right with right).
- Do not bundle power cords together with connection cables. Doing so can result in humming or noise.
- Do not connect the unit to the PHONO input connectors on the amplifier.

Preparations

Connecting cables

Select the cables according to the equipment being connected.

Audio cables

Analog connections (stereo)



Audio cable (supplied)

Analog connections

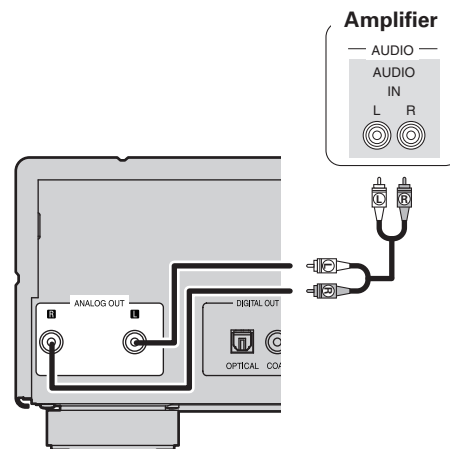

Connecting the power cord

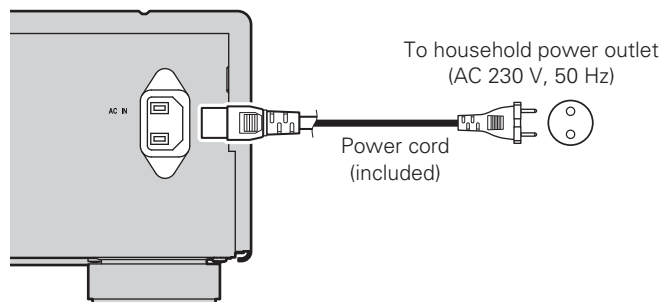

NOTE

- Insert the plugs securely. Loose connections will result in the generation of noise.
- Do not unplug the power cord while the unit is operating.

Basic operation

Symbols used to indicate buttons in this manual

- Button located on both the main unit and the remote control → **BUTTON**
- Button only on the main unit → **<BUTTON>**
- Button only on the remote control → **[BUTTON]**

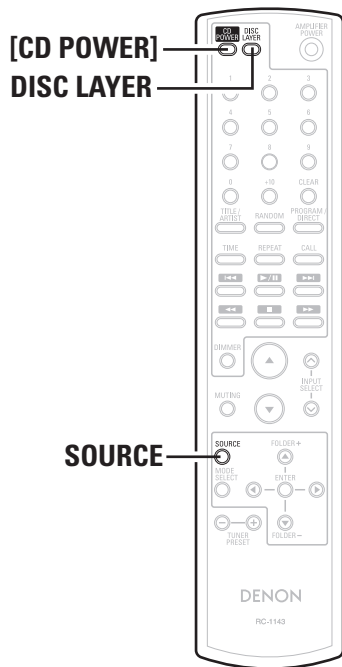
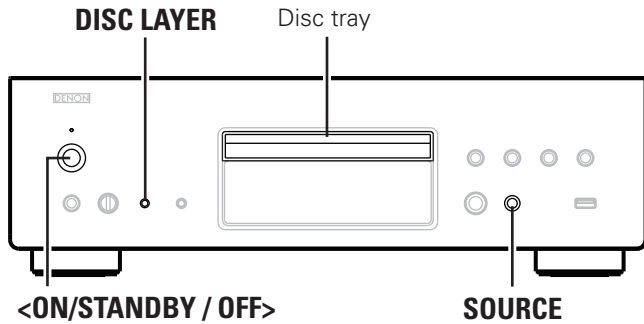

Before use

Setting the top priority playback layer for super audio CDs

- The layer that is played with priority when the disc is loaded can be set.
- Upon purchase, the priority layer is set to the "STEREO".

1 Turn the power on.
(Press **<ON/STANDBY / OFF>**.)

2 Check that no disc is loaded.

- If the layer is switched while a disc is in the player or the disc tray is opened, the playback layer switches for that disc, but the top priority playback layer setting itself does not change.

3 Press SOURCE to set the playback media mode to "DISC".

4 Press DISC LAYER and switch to the layer you want to set (Super Audio CD only).

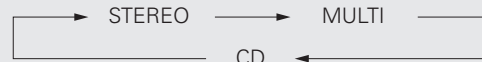

[Selectable items]

- STEREO** : Plays back the 2-channel area of the Super Audio CD (the default setting).
- MULTI** : Plays back the multi-channel area of the Super Audio CD. The analog output is altered to a down-mixed 2-channel signal.
- CD** : Plays back the CD layer of the Super Audio CD.

- When a disc is loaded after the setting has been made, the contents recorded on the unit layer are displayed.
- If a disc that does not contain the layer set for top priority playback is loaded, the contents recorded on another layer are displayed automatically.
- This setting is stored in the memory and is not cleared even when the disc holder is opened or closed or the power is turned off. To change the setting, repeat the procedure above.



- During playback of the multi-channeled source, the analog output of the unit plays back a 2-channel downmix.
- If the area and layer have not been set for a disc, the priority playback order is as follows:

① STEREO ② MULTI ③ CD

- This setting is memorized and is retained even if the disc tray is opened/closed or the power is switched on/off. Please reconfigure the settings if you wish to change them.

NOTE

Do not place any foreign objects in the disc tray. Doing so could damage it.

Turning the power off

1 Press [CD POWER].
The power is set to the standby mode.

2 Press <ON/STANDBY / OFF>.
The power indicator turns off, and so does the power.



Make sure that the disc tray is completely shut before turning off the power.

NOTE

Power continues to be supplied to some of the circuitry even when the power is in the standby mode. When leaving home for long periods of time or when going on vacation, either press **<ON/STANDBY / OFF>** to turn off the power, or unplug the power cord from the power outlet.

Symbols used to indicate buttons in this manual

- Button located on both the main unit and the remote control → **BUTTON**
- Button only on the main unit → **<BUTTON>**
- Button only on the remote control → **[BUTTON]**

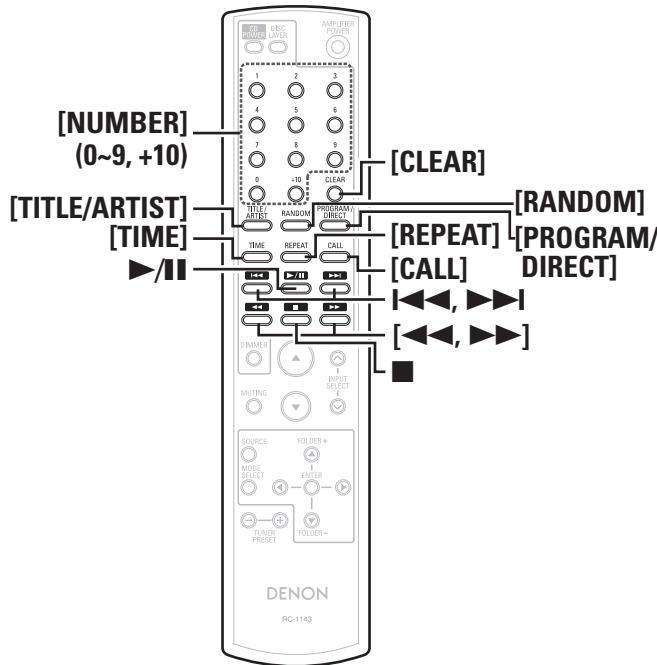
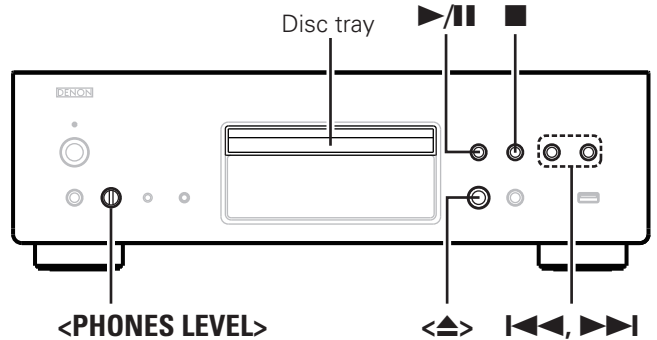

Playback CDs

Playing CDs

1 Load a disc.

- To open or close the disc tray, press **<▲>**.
- The disc tray can also be closed by pressing **▶/||**.



Make sure that the disc tray is completely shut before turning off the power.

2 Playback preparation.

(☞ page 7 “Setting the top priority playback layer for Super Audio CDs”)

3 Press ▶/||.

The “▶” indicator lights and playback begins.

Stopping Playback

Press **■**.

Stopping Playback temporarily

Press **▶/||**.

The “||” indicator lights.

- To resume playback, press **▶/||**.

Fast-Forwarding and Fast-Reversing (searching)

During playback, press and hold in **[◀◀, ▶▶]**.

Moving to the Beginning of Tracks (skipping)

During playback, press **[◀◀, ▶▶]**.

- The disc is skipped the number of tracks equal to the number of times the button is pressed.

- When pressed once in the return direction, playback returns to the beginning of the currently playing track.

Playing a Specific Track (Remote Control Only)

Press **[NUMBER] (0 – 9, +10)** to select the track.

[Example] : Track 4 : **[4]**

[Example] : Track 12 : **[+10], [2]**

[Example] : Track 20 : **[+10], [+10], [0]**

Displaying text (Super Audio CD only)

- The player can display the textual information of Super Audio CDs that contain it while either stopped or playing.
- The album title, artist name and track titles can be displayed.
- The player can display capital and small letters, numbers and some symbols.

In the stop mode, press [TITLE/ARTIST].



- The display switches each time the button is pressed.



Press **[TIME]** to switch to the display of the recorded time while text information is being displayed.

Listening with headphone

Plug the headphones (sold separately) into the PHONES jack.

Adjusting the Volume

Turn **<PHONES LEVEL>**.

NOTE

To prevent hearing loss, do not raise volume level excessively when using headphones.

Playing repeatedly (Repeat playback)

Press **[REPEAT]**.

Playback in the respective repeat mode starts.

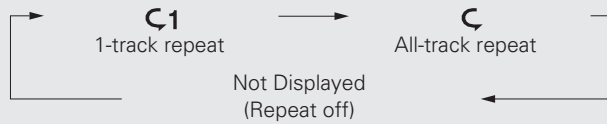

[Selectable items]

C1 (1-track repeat) : Only 1 track is played repeatedly.

C (All-track repeat) : All tracks are played repeatedly.

Not Displayed (Repeat off) : Normal playback resumes.

Playing in random order (Random playback)

1 In the stop mode, press **[RANDOM]** until “RAND” is lights.

2 Press **▶/II**.
The tracks start playing in random order.

Stopping Random Playback

While stopped, press **[RANDOM]** once.
The “RAND” indicator turns off.

NOTE

- Direct searching is not possible during random playback.
- If **[REPEAT]** is pressed during random playback, after the current session of random playback is finished, another session in a different order of tracks starts.

Playing tracks in a specific order (Program playback)

Up to 20 tracks can be programmed.

1 In the stop mode, press **[PROGRAM/DIRECT]** until “PROG” is lights.

2 Use **[NUMBER]** (0 – 9, +10) to select the tracks.
[Example]
To program tracks 3, 12, 7 to play in that order:
Press **[3]**, **[+10]**, **[2]**, **[7]**.

3 Press **▶/II**.
Playback starts in the programmed order.

Checking the order of the programmed tracks

While stopped, press **[CALL]**.
The track numbers are displayed in the programmed order each time the button is pressed.

To clear the last track programmed

While stopped, press **[CLEAR]**.
The last track programmed is cleared each time the button is pressed.

Clearing the all programmed track

While stopped, press **[PROGRAM/DIRECT]**.



- If **[REPEAT]** is pressed during program playback, the tracks are played repeatedly in the programmed order.
- Programmed playback is not possible with MP3/WMA discs.

Advanced connections

Preparations

Connecting cables

Select the cables according to the equipment being connected.

Audio cables

Optical digital connections



Optical cable (sold separately)

Coaxial digital connections



Coaxial digital cable (sold separately)

iPod connections



iPod cable (sold separately)

Digital connections

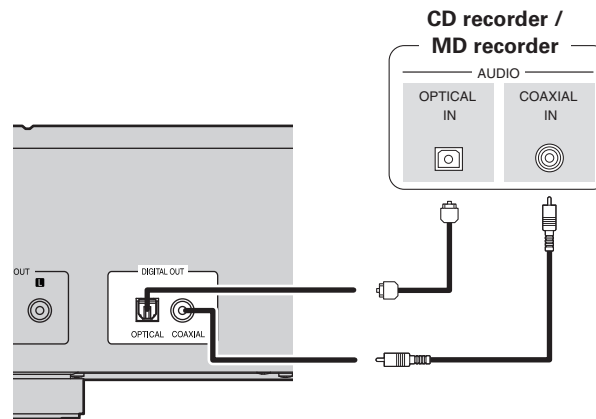

When connecting the optical digital output connector with an optical transmission cable (sold separately)

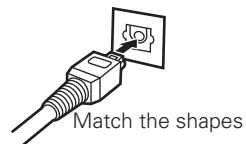

Match the shapes then insert firmly.

USB port connections

USB memory device

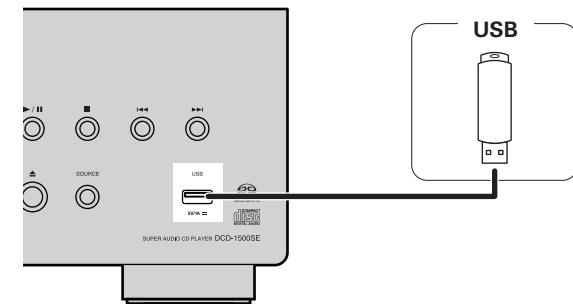

NOTE

- Do not use an extension cable when connecting a USB Memory device.
- A computer can not be connected to and operate the unit via its USB port.
- For details about USB memory devices, see "Playable USB Memory Formats" (page 15).

iPod

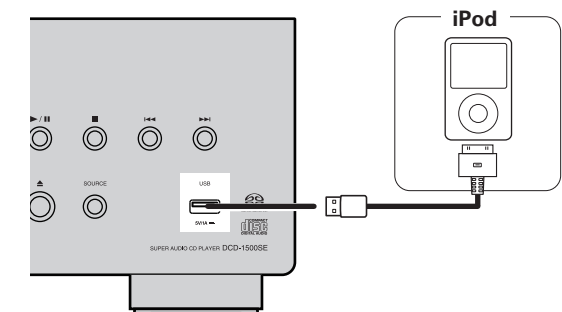

- To connect an iPod to the unit, use the USB cable supplied with the iPod.
- With this unit, playback via iPod (5th generation or later), iPod touch, iPod classic, or iPod nano can be performed. For details, check the Web (www.denon.com).

Advanced operations

Symbols used to indicate buttons in this manual

- Button located on both the main unit and the remote control → **BUTTON**
- Button only on the main unit → **<BUTTON>**
- Button only on the remote control → **[BUTTON]**

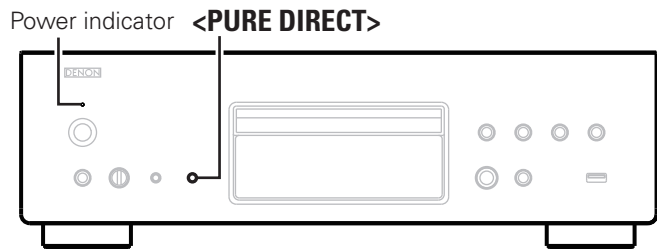

Operations possible during playback

Switching the display's brightness

Press **[DIMMER]**.

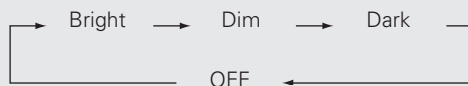

- The display's brightness switches each time the button is pressed.

Switching the pure direct mode

In the stop mode, press **<PURE DIRECT>**.

- In Pure Direct Mode, the unit is in the following state:
 - Display: OFF
 - Digital output: OFF

Eco mode setting

With the Eco mode ON, this unit will automatically enter the standby mode after about 30 continuous minutes of stop mode with no operation. During standby mode with the Eco mode ON, the Power indicator is unlit to reduce power consumption.

Press and hold [CD POWER] on the remote control for at least 5 seconds.

- Eco mode is switched between On and Off.
- The Power indicator indicates Eco mode On/Off during Standby, as shown below.

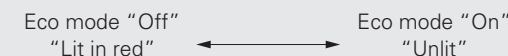

- The Power indicator flashes in red during Eco mode setting.



- If you set the Eco mode while the unit is ON, the unit will enter the standby mode as soon as the Eco mode setting is completed.
- The default setting for the Eco mode is OFF.

NOTE

If an iPod is connected with this unit in the remote mode, this unit will not enter the standby mode, even after about 30 continuous minutes of stop mode with no operation.

To change time display

Press **[TIME]**.

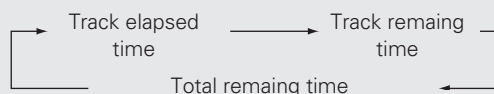

- When **[TIME]** is pressed each time, the display shows differently in the following orders.
 - Time display can be changed only when a CD or Super Audio CD is being played.
 - During playback via USB/iPod, only track elapsed time is displayed.

Symbols used to indicate buttons in this manual

Button located on both the main unit and the remote control → **BUTTON**
 Button only on the main unit → **<BUTTON>**
 Button only on the remote control → **[BUTTON]**

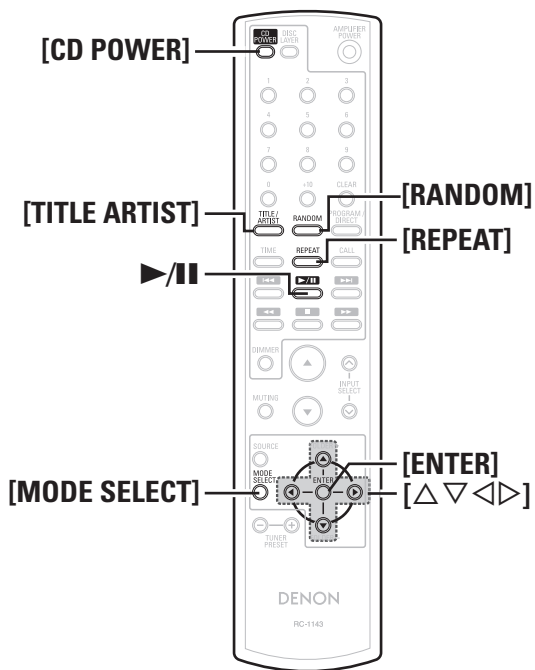
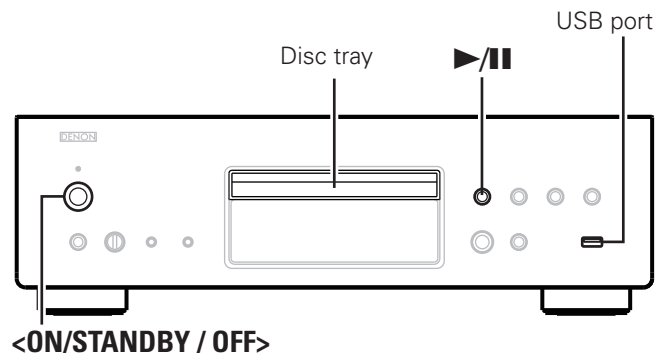

Before playing a USB or an iPod

- 1 Turn the power on.**
(Press **<ON/STANDBY / OFF>**.)
- 2 Connect a USB memory device or iPod connection cable.**
 - When a USB memory device or iPod is connected to the USB port on the unit, the source media mode automatically switches to "USB" and file playback begins.

The playback media mode setting remains in the memory, even when the power is set to standby.

Setting the power to the standby mode

Press **[CD POWER]**.

Canceling the standby mode

Press **[CD POWER]** again.

Turning the power off

Press **<ON/STANDBY / OFF>**.

NOTE

Be sure to stop playback before turning the power off.

Playback of MP3 and WMA files

There are many music distribution sites on the Internet allowing you to download music files in MP3 or WMA (Windows Media® Audio) formats. The music (files) downloaded from such sites can be stored on CD-R or CD-RW discs and played on the unit.

"Windows Media" and "Windows" are registered trademarks or trademarks of Microsoft Corporation in the United States and other countries.

MP3 and WMA formats

CD-R and CD-RW discs created in the format described below can be played.

Writing software format

- ISO9660 level 1
 - When written in other formats, it may not be possible to play the disc properly.

Maximum number of playable files and folders

Total number of folders and files : 1000
 Number of folders : 255

File formats

MP3 (MPEG-1 Audio Layer-3)
 WMA (Windows Media Audio)

Tag data

ID3-Tags (Ver. 1.x and 2.x)
 META-Tags
 (Compatible with title, artist and album names)

Playable MP3/WMA file			
File format	Sampling frequency	Bit rate	Extension
MP3	32, 44.1, 48 kHz	32 – 320 kbps	.mp3
WMA	32, 44.1, 48 kHz	64 – 160 kbps	.wma

- Only music files that are not copyright-protected can be played on this unit.
- Be sure to give files the extension ".MP3" or ".WMA". Files with any other extensions or with no extensions cannot be played.
- In accordance with copyright laws, recordings you have made should only be used for your personal enjoyment and may not be used in other ways without permission of the copyright holder.

Folder mode and disc mode settings

Press **[MODE SELECT]** to switch the range of files to be played.

Folder mode

The "WMA" or "MP3" indicator flashes.
 The files in the selected folder are played.

Disc mode

The "WMA" or "MP3" indicator lights.
 All the files on the disc are played.

Playing MP3 and WMA files

- 1 Load a CD-R or CD-RW disc containing music files in the MP3 or WMA formats into the disc tray.** (☞ page 2).
- 2 Press [MODE SELECT] to select the folder mode or disc mode.**
 - Refer to "Folder mode and disc mode settings" (☞ page 12).
- 3 Press ►/||.**
 Playback starts.

Changing the folder to be played

Use [Δ, ▽] to select the desired folder, and then press [ENTER].

Changing the file to be played

Use [◀, ▶] to select the desired file, and then press [ENTER].



When a folder is selected, playback switches to the first track of the selected folder.

Switching the Display

During playback, press [TITLE/ARTIST].



- With the unit, the folder and file names can be displayed like titles. Up to 11 characters consisting of numbers, letters and the underscore can be displayed. Characters that cannot be displayed are replaced with asterisks.
- The player can display the following characters.

A-Z a-z 0-9

! " # \$ % & ; : < > ? @ \ [] _ ` | { } ~ ^ ' () * + , - . / = (space)

MP3 or WMA playback order of MP3 or WMA files

When there are multiple folders containing MP3 or WMA files, the playback order of folders is automatically set when this unit reads the media. The files in each folder are played back in the order in which the files were recorded on the media, from the oldest date and time.

□ Playback order of folders

CD-R/CD-RW

For playback of files on CD-R or CD-RW, files in all folders on the first layer are played first, next on the second layer, then next on the third layer, and so on in this order.

USB memory device

For playback of files recorded on USB, files in the first folder on the first layer are played first, next folders on the second layer in the folder, then next on the third layer, and so on in this order. Then accordingly files on another first layer are played.



- The playback order displayed on a PC may differ from the actual playback order.
- The playback order with a CD-R/CD-RW may differ, depending on the writing software.

NOTE

The playback order may differ from the order in which the folders or files were recorded if you delete or add a folder or file on USB. This occurs because of data recording specifications and is not a malfunction.

□ Playing to MP3 or WMA files in random order (Random playback)

1 Press [MODE SELECT] to select the disc mode.

- Refer to "Folder mode and disc mode settings" (page 12).

2 While stopped, press [RANDOM].

The "RAND" indicator lights.

3 Press ▶/II or [ENTER].

Tracks are selected and played automatically in random order.

Canceling random playback

While stopped, press [RANDOM].

- The "RAND" indicator turns off.

□ Playing to MP3 or WMA files repeatedly (Repeat playback)

1 Press [MODE SELECT] to select the folder mode or disc mode.

- Refer to "Folder mode and disc mode settings" (page 12).

2 Press [REPEAT] to select the repeat mode.

Playback in the respective repeat mode starts.

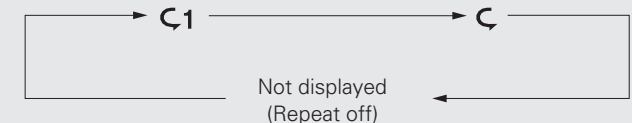

3 Press ▶/II.

Either the files in the selected folder or all the files on the disc are played repeatedly.

Canceling repeat folder/disc playback

Press [REPEAT] until the "C" indicator turns off.

Symbols used to indicate buttons in this manual

Button located on both the main unit and the remote control → **BUTTON**
 Button only on the main unit → **<BUTTON>**
 Button only on the remote control → **[BUTTON]**

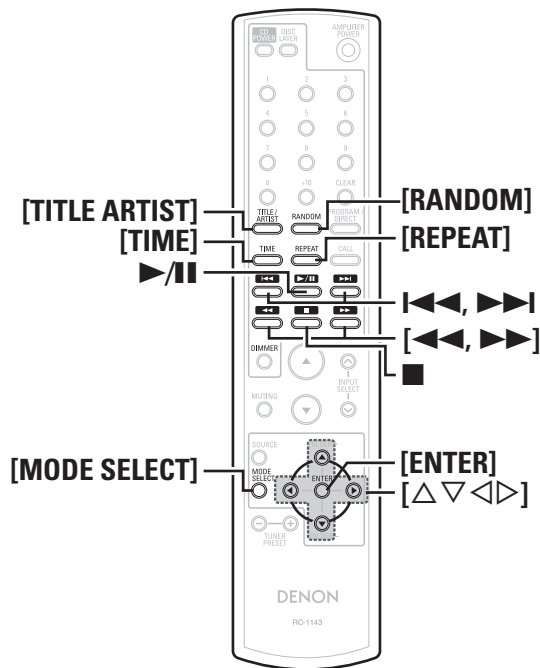
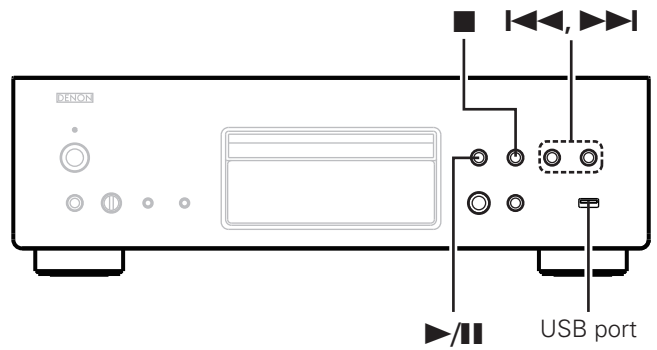

Playback iPod®

With the unit, you can listen to music on an iPod and you can also operate the iPod with the main unit or the remote control.



“Made for iPod” means that an electronic accessory has been designed to connect specifically to iPod and has been certified by the developer to meet Apple performance standards.

Apple is not responsible for the operation of this device or its compliance with safety and regulatory standards.

iPod is a trademark of Apple Inc., registered in the U.S. and other countries.

- The iPod may only be used to copy or play contents that are not copyrighted or contents for which copying or playback is legally permitted for your private use as an individual. Be sure to comply with applicable copyright laws.

Playing iPod®

1 Playback preparation (☞ page 12 “Before Playing USB or an iPod”).

2 Press [MODE SELECT] to select the display mode.
The mode switches each time the button is pressed.

Display mode		Browse mode	Remote mode
Display location		Main unit display	iPod display
Playable files	Audio file	○	○
	Video file	×	○
Active buttons	Remote control and Main unit (This unit)	○	○
	iPod	×	○

3 Use [Δ ∇] to select the item, then press [ENTER] or [▷] to select the music file to be played.

4 Press ▶/||.
Playback starts.

Remote control and iPod button relations

Remote control buttons	iPod buttons	Operation on the unit
▶/	▶/	Plays the track ※ Play/Pause in remote mode
◀◀, ▶▶	◀◀, ▶▶	Plays the track from the beginning / Plays the next track
◀◀, ▶▶ (Press and hold) ◀◀, ▶▶	◀◀, ▶▶ (Press and hold)	Fast-reverses the track / Fast-forwards the track
Δ, ∇	Click Wheel	Selects an item
ENTER or ▷	Select	Enters the selection or plays the track
MODE SELECT	-	Switches between the browse mode and the remote mode
REPEAT	-	Switches the repeat function
RANDOM	-	Switches the shuffle function
◀	MENU	Displays the menu or return to the previous menu

NOTE

- DENON will accept no responsibility whatsoever for any loss of iPod data.
- Depending on the type of iPod and the software version, some functions may not operate.

To Switch the Display (Browse mode only)

During playback, press [TITLE/ARTIST].
The display switches each time the button is pressed.



Switching the Time Display

Press [TIME].

Disconnecting the iPod

1 Press ■.

2 Disconnect the iPod cable from the USB port.

USB playback

Playable USB memory formats

Files created in the following formats and stored on a USB memory device can be played.

❑ USB-Compatible file systems

“FAT16” or “FAT32”

- If the USB memory device is divided into multiple partitions, only the top drive can be selected.

❑ Maximum number of playable files and folders

Maximum number of files in a folder: 255

Maximum number of folders: 255

❑ File format

MP3 (MPEG-1 Audio Layer-3)

WMA (Windows Media Audio)

❑ Tag data

ID3-Tags (Ver.1.x and 2.x)

META-Tags

(Compatible with title, artist and album names)

Playable MP3/WMA file			
File format	Sampling frequency	Bit rate	Extension
MP3	32, 44.1, 48 kHz	32 – 320 kbps	.mp3
WMA	32, 44.1, 48 kHz	64 – 192 kbps	.wma



Only music files that are not copyright-protected can be played on this set.

- Contents downloaded from pay sites on the Internet are copyright protected. Also, files encoded in WMA format when ripped from a CD, etc., on a computer may be copyright protected, depending on the computer’s settings.

Playing USB memory devices

1 Playback preparation (“Before Playing a USB or an iPod” page 12).

2 Press [MODE SELECT] to select the folder mode or disc mode.

- Refer to “Folder mode and disc mode settings” (page 12).

3 Press ►/II. Playback starts.

To Switch the Folder or File During Playback

• Folder

Use [Δ, ▽] to select the folder, then press [ENTER].

• File

Use [◀, ▶] to select the file, then press [ENTER].

Use I◀◀, ▶▶I to select the file.

- The file numbers are set automatically when the USB memory device is loaded.

Stopping Playback

Press ■.

Stopping Playback temporarily

Press ►/II.

The “II” is displayed.

- To resume playback, press ►/II.

Fast-Forwarding and Fast-Reversing (searching)

During playback, press and hold in [◀◀, ▶▶].

Playing repeatedly (Repeat playback)

Press [REPEAT].

Playing in random order (Random playback)

While stopped, press [RANDOM].

- Random playback will automatically start when you press [ENTER] or ►/II.
- To cancel random playback, press [RANDOM] during Stop mode. The “RAND” indicator goes dark and random playback is canceled.

Switching the Display

During playback, press [TITLE/ARTIST].

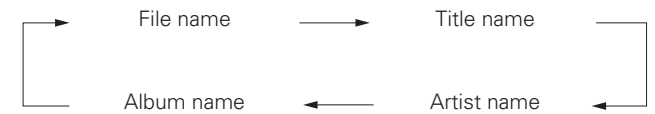

- The player can display the following characters:

A – Z | a – z | 0 – 9

! " # \$ % & ; < > ? @ | | _ ` | { } ~ ^ ' () * + , - . / = (space)

Switching the Time Display

Press [TIME].

NOTE

- DENON will take no responsibility whatsoever for any loss or damage to data on a USB memory device when using it connected to the unit.
- USB memory devices will not work via a USB hub.
- DENON does not guarantee that all USB memory devices will operate or be supplied power. When using a USB portable hard disk that can draw power from an AC adapter, we recommend using the AC adapter.

Using the timer play function

- 1** Turn on the power of the connected components.
- 2** Switch the amplifier's function to input from the connected main unit.
- 3** Load a disc or connect a USB memory device or iPod.
- 4** Set the audio timer for the desired times.
 - Refer also to the owner's manual of the audio timer.
- 5** Turn the timer "ON".
 - The power of the components connected to the timer turns off.
 - When the set time is reached, the power of the different components automatically turns on and playback starts.

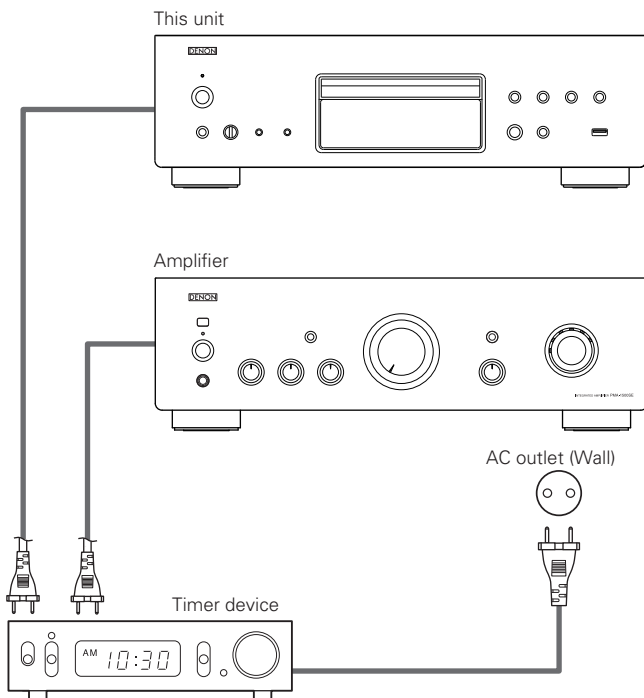

Explanation of terms

B

Bit rate

This expresses the read amount per 1 second of video/audio data recorded in a disc.

M

MP3 (MPEG AudioPlayer 3)

This is an internationally standardized audio data compression scheme, using the "MPEG-1" video compression standard. It compresses the data volume to about one eleventh its original size while maintaining sound quality equivalent to a music CD.

P

Pure direct

This function enables higher-quality playback of audio signals, by turning off the display and digital output to eliminate any slight effect they may have on the audio circuits.

S

Sampling frequency

Sampling involves taking a reading of a sound wave (analog signal) at regular intervals and expressing the height of the wave at each reading in digitized format (producing a digital signal).

The number of readings taken in one second is called the "sampling frequency". The larger the value, the closer the reproduced sound is to the original.

Super audio CD

There are three types of Super Audio CDs:

- ① Single layer discs
Single layer Super Audio CD with just an HD layer.
- ② Dual layer discs
Super Audio CD with a double HD layer, offering extended playing time and high sound quality.
- ③ Hybrid discs
Two-layer Super Audio CD with an HD layer and a CD layer.
The signals on the CD layer can be played on a regular CD player.

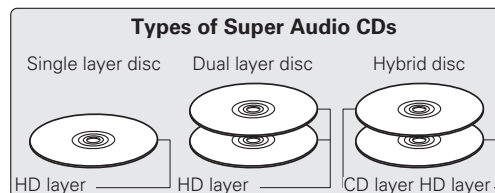

• What is the HD layer?

The HD layer is a layer of high density signals for Super Audio CDs.

• What is the CD layer?

The CD layer is the layer of signals that can be read on a regular CD player.

W

WMA (Windows Media Audio)

This is audio compression technology developed by Microsoft Corporation.

WMA data can be encoded using Windows Media® Player Ver.7, 7.1, Windows Media® Player for Windows® XP and Windows Media® Player 9 Series.

To encode WMA files, only use applications authorized by Microsoft Corporation. If you use an unauthorized application, the file may not work properly.

Troubleshooting

If a problem occurs, first check the following:

1. Are the connections correct?

2. Is the unit being operated as described in the owner's manual?

If this unit does not operate properly, check the items listed in the table below. If the problem persists there may be a malfunction.

In this case, disconnect the power immediately and contact the retail outlet.

[General]

Symptom	Cause	Countermeasure	Page
Disc tray does not open.	• The power is not on.	• Turn on the power.	7
"NO DISC" is displayed even though a disc is loaded.	• The disc is not properly loaded.	• Reload the disc.	2
"TRACK 0 0m00s" is displayed even though a disc is loaded.	• The loaded disc is not a CD.	• Load a CD.	2
Playback does not start even when the ►/ button is pressed.	• The disc is dirty or scratched.	• Wipe the dirt off the disc or replace the disc.	3
No sound is produced or sound is distorted.	• The output cables are not properly connected to the amplifier. • The amplifier's function setting or adjustments are not right.	• Check the connections. • Check the amplifier's functions and controls and adjust as necessary.	6,10 –
A specific section of a disc does not play properly.	• The disc is dirty or scratched.	• Wipe the dirt off the disc or replace the disc.	3
Programmed playback is not possible.	• The tracks have not been programmed properly. • Programmed playback is not possible with MP3 and WMA files.	• Program properly.	9
		• Use a CD.	9
A CD-R or CD-RW disc cannot be played.	• The disc has not been finalized. • The recording conditions and/or the quality of the disc itself are poor.	• Finalize the disc then play it.	2
		• Use a properly recorded disc.	2

Symptom	Cause	Countermeasure	Page
The unit does not operate properly when the remote control is operated.	• The batteries are dead.	• Replace the batteries with new ones.	3
	• The remote control is too far from the unit.	• Move the remote control closer to the unit.	3
File recorded in MP3 or WMA formats cannot be played.	• You have selected a copyright-protected WMA file or a file that cannot be played normally.	• Use the ◀, ▶ button on the remote control to select a different file.	13

[iPod]

Symptom	Cause	Countermeasure	Page
The iPod cannot be played.	• Cable is not properly connected.	• Reconnect.	10

[USB]

Symptom	Cause	Countermeasure	Page
When a USB memory device is connected, "NO DEVICE" is displayed.	• The unit cannot recognize a USB memory device.	• Check the connection.	10
	• A USB memory device not conforming to mass storage class or MTP standards is connected.	• Connect a USB memory device conforming to mass storage class or MTP standards.	–
	• A USB memory device that the unit cannot recognize is connected.	• This is not a malfunction. DENON does not guarantee that all USB memory devices will operate or receive power. • Connect the USB memory device directly to the USB port.	–
Files on a USB memory device cannot be played.	• The USB memory device is connected via USB hub.	• Connect the USB memory device directly to the USB port.	–
	• The USB memory device is in a format other than FAT16 or FAT32.	• Set the format to FAT16 or FAT32. For details, refer to the USB memory device's operating instructions.	–
	• The USB memory device is divided into multiple partitions.	• When divided into multiple partitions, only files stored in the top partition can be played.	–
	• Files are stored in a non-compatible format.	• Record the files in a compatible format.	15
	• You are attempting to play a file that is copyright protected.	• Files that are copyright protected cannot be played on this unit.	15

Specifications

Audio performance

• Analog output

Channels:	2 channels	2 channels
Playable frequency range:	2 Hz – 100 kHz	2 Hz – 20 kHz
Playable frequency response:	2 Hz – 50 kHz (–3 dB)	2 Hz – 20 kHz
S/N:	117 dB (Audible range)	117 dB
Dynamic range:	113 dB (Audible range)	100 dB
Harmonic distortion:	0.0010 % (1 kHz, Audible range)	0.0018 % (1 kHz)
Wow & flutter:	Below measurable limits	Below measurable limits
Output level:	2.0 V (10 kΩ)	2.0 V (10 kΩ)
Signal type:	1-bit DSD	16-bit linear PCM
Sampling frequency:	2.822 MHz	44.1 kHz
Usable discs:	Super Audio CD	Compact Disc

[Super Audio CD]

[CD]

Channels:	2 channels
Playable frequency range:	2 Hz – 20 kHz
Playable frequency response:	2 Hz – 20 kHz
S/N:	117 dB
Dynamic range:	100 dB
Harmonic distortion:	0.0018 % (1 kHz)
Wow & flutter:	Below measurable limits
Output level:	2.0 V (10 kΩ)
Signal type:	16-bit linear PCM
Sampling frequency:	44.1 kHz
Usable discs:	Compact Disc

General

Power supply:	AC 230 V, 50 Hz
Power consumption:	30 W
	Standby: 0.2 W or less
	Eco Standby: 0.1 W
Maximum external dimensions:	434 (W) x 135 (H) x 331 (D) mm
Weight:	8.0 kg

Remote control (RC-1143)

Remote control method:	Infrared pulse method
Power supply:	R03/AAA Type (two batteries)
Maximum external dimensions:	49 (W) x 220 (H) x 21 (D) mm
Weight:	110 g (including batteries)

※ For purposes of improvement, specifications and design are subject to change without notice.

Index

☞ Numerics

1-track repeat 9

☞ A

All-track repeat 9
 Analog connections 6
 Audio cable 6

☞ B

Batteries 3
 Browse mode 14

☞ C

Connecting cables 6, 10
 Connection
 Analog Connections 6
 Coaxial digital connections 10
 iPod connections 10
 Optical digital connections 10
 Power cord 6
 CD-R/CD-RW 2
 CD layer 16
 Coaxial digital cable 10

☞ D

Digital connections 10
 Disc mode 12
 Display 4
 Display's brightness 11
 Dual layer disc 16

☞ E

Eco mode 11
 Extension 12, 15

☞ F

Fast-forwarding 8, 15
 Fast-reversing 8, 15
 File format 12, 15
 Finalise 2
 Folder mode 12

☞ H

HD layer 16
 Hybrid disc 16

☞ I

iPod 14

☞ M

Moving to the beginning of tracks 8
 MP3 12, 13, 15, 16
 Music CDs 2

☞ O

Optical cable 10

☞ P

Playback
 Playing CDs 8
 Playing in random order 9, 13, 15
 Playing repeatedly 9, 13, 15
 Playing tracks in a specific order 9
 Stopping playback 8, 15
 Stopping playback temporarily 8, 15
 Power cord 6
 Priority playback layer 7
 Program playback 9
 Pure direct mode 11

☞ R

Random playback 9, 13, 15
 Remote control 5
 Inserting the batteries 3
 Remote mode 14
 Repeat playback 9, 13, 15

☞ S

Searching 8, 15
 Single layer disc 16
 Skipping 8
 Stopping playback 8, 15
 Stopping playback temporarily 8, 15
 Super Audio CD 2, 16

☞ T

Tag data 12, 15
 Timer play function 16

☞ U

USB memory device 10, 15

☞ W

WMA 12, 13, 15, 16



DENON

www.denon.com

D&M Holdings Inc.
Printed in Japan 5411 10407 207D